



600 Eleventh Street NW
Grand Rapids, MI 49504
Phone: (800) 888-9768 (616) 235-0140
Fax: (616) 235-2901 Email: info@dacindustries.com
www.dacindustries.com

Part # 6040 Deluxe Exit Bar Kit Installation Guide

Materials Included:

Mounting Plate - 2 pieces with inner and outer plate (reversible)
8 tek-screws, stainless steel
1 - exit bar
1 - receiver plate and strike
1 - 3/8" u-bolt stainless steel
2 - flat washers
2 - cap nuts, stainless steel
4 - 1/4" X 3/4" machine screws w/nylon lock nuts
2 - 1/4" X 3/4" machine screw for strike
2 - 3/16" X 1/2" flat head machine screw for lock box
Lock box and key cylinder with back plate and screws

Tools Recommended:

Hammer
Center Punch
Electric Drill w 3/8" socket
Magnetic Torpedo Level
Adjustable Wrench
Combination Screw Driver

Determine gate width allowing approximately 1" for the latch side of the gate plus an allowance for the gate hinges you are using. **Be sure to include a horizontal brace in the area of the mounting plate.** Ornamental gates should not need horizontal bracing.

Outside plate can be reversed for either left or right hand installation. Mounting plate will slide to proper width. Plate will be installed on inside of gate frame.

Take lock box and insert into slots on plate and install two 3/16" flat-head screws to hold in place. Install cylinder into lock box by using cylinder back plate and screws. **Be sure key position allows for key removal.** Install exit bar onto mounting plate using 2 machine screws

with nylon locknuts. If the exit bar is too wide to fit gate, cut end of bar to make shorter. Prime and paint cut end.

Attach mounting plate to gate by using tek-screws (Hint - drilling pilot hole first into thick wall pipe will make it easier to install tek-screws). Exit bar height is approx. 42" to floor. **Check your local code.**

Drill two 1/4" holes through mounting plate where needed for back support bracket.

Turn gate over and cut out tension bar covering lock box and trim and knuckle fabric by lock box area.

Install strike latch onto receiver bracket using 2 machine screws provided. After mounting plate and exit bar are installed on gate, install receiver bracket on latch post by using u-bolt with flat washer and cap nuts. Adjust so that exit bar latch hits the strike and the dead latch hits outside the catch area. Check for smooth operation and engagement. Install two tek-screws through receiver into post.

***The installation of a transom over gate for added stability is recommended.**

Part #6040 - Deluxe Exit Bar Kit Installation



1. Determine left or right hand installation. Outer plate is reversible.



2. Install lock box and key cylinder



3. Use back plate with screws to hold key cylinder. ***Be sure key position allows for key removal. If cylinder is installed incorrectly, key cannot be removed!**

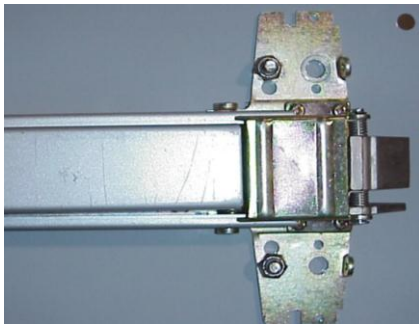

4. Mount exit bar to mounting plate.



5. Slide plate to width of gate and attach to frame.



6. Drill holes through plate and install back mounting bracket. Finish with end cap.



7. Cut and remove tension bar. Cut and knuckle fabric.

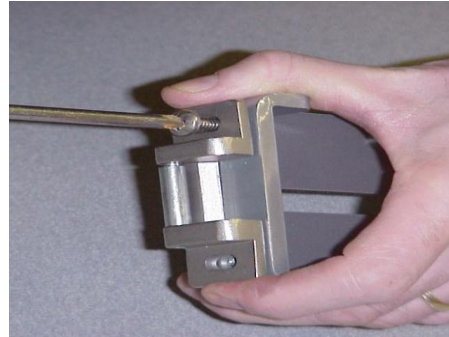

8. Screw strike latch to latch bracket.



9. After latch bracket is adjusted properly, attach to post with tek-screws.

DAC Industries, Inc.

Phone (800) 888-9768

www.dacindustries.com

EXIT DOOR HARDWARE

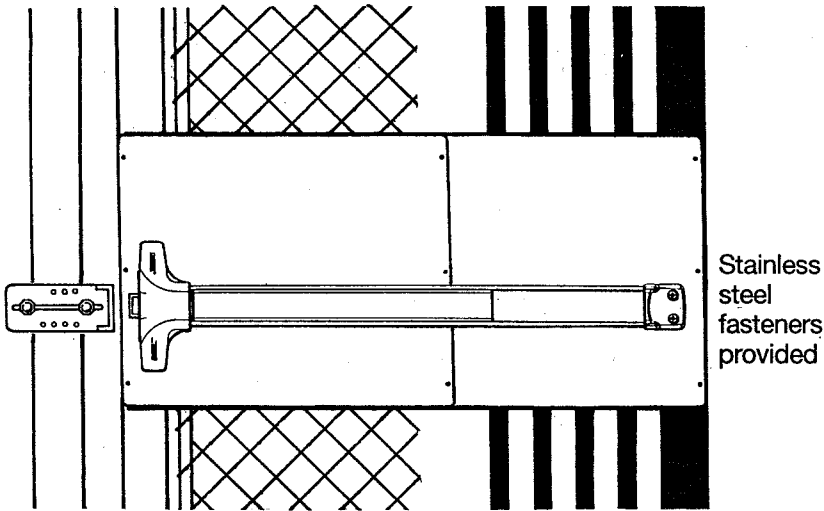

CHAIN LINK GATE - OR - ORNAMENTAL GATE

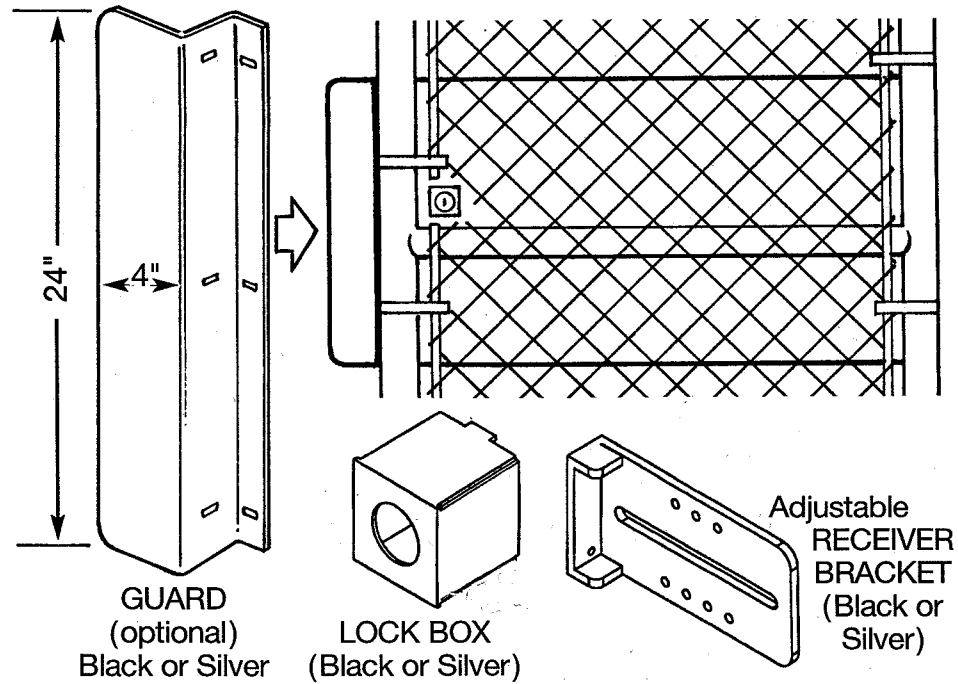
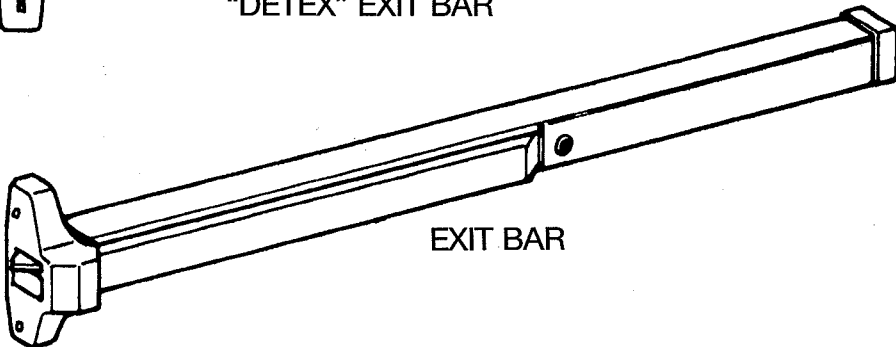
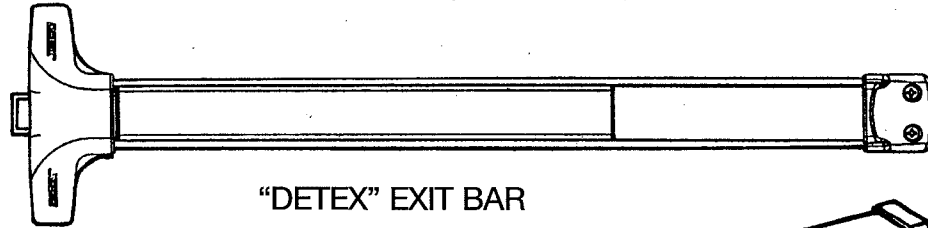
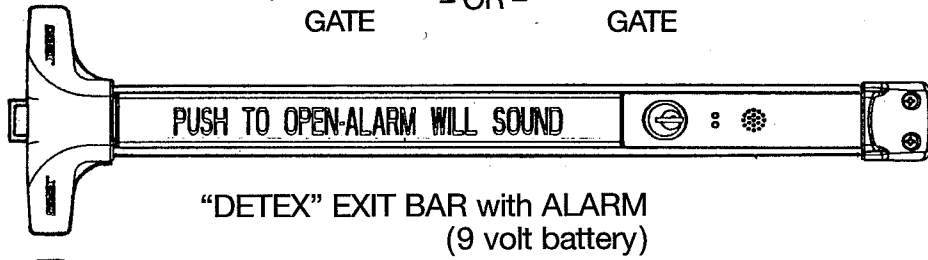
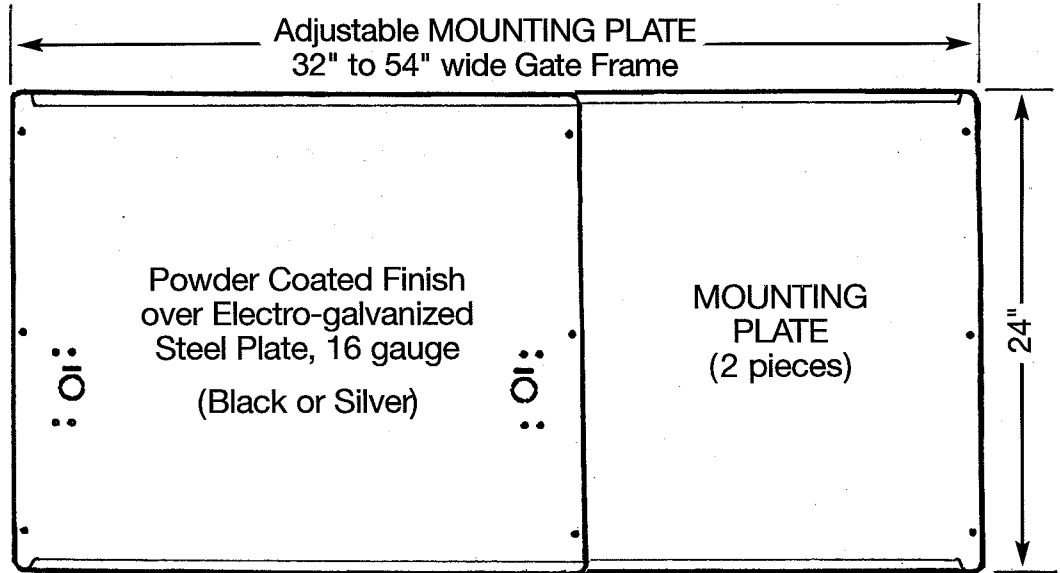

EXIT DOOR HARDWARE		 1-800-888-9768 www.dacindustries.com
JOB / PROJECT	DATE	
		_____ OF _____

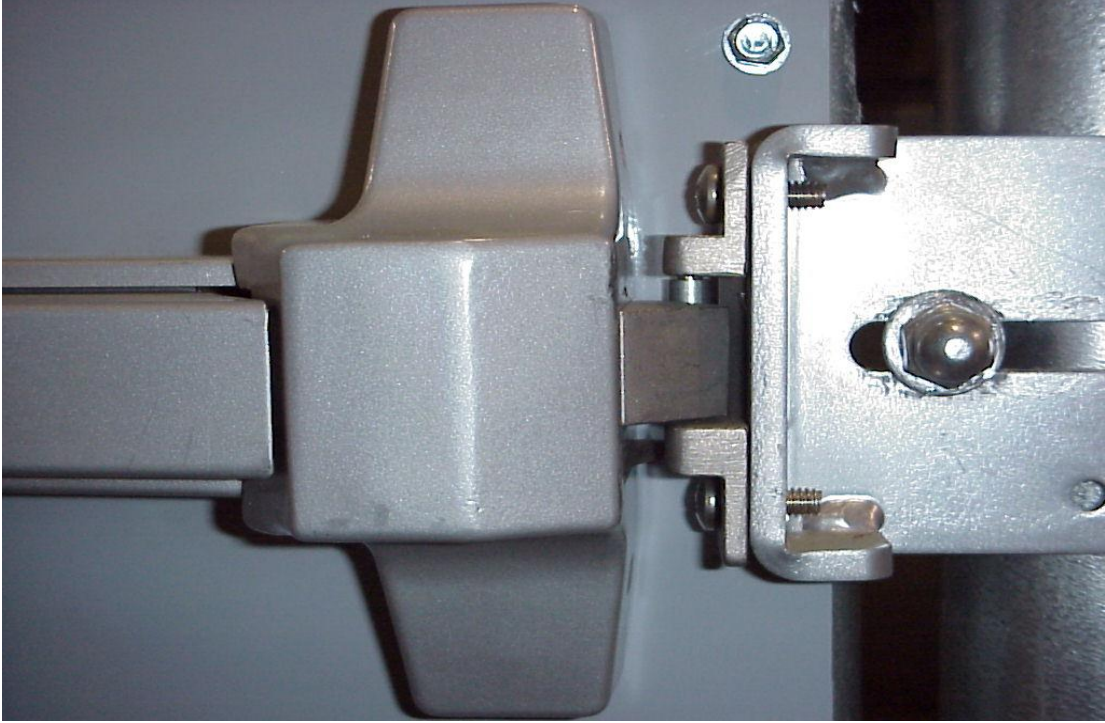

Receiver must act as a gate stop.



Guards are available for extra security or for gaps greater than 1" at an additional cost.

